

# Shaving Dovetail Tool Holder

## Round Shank Type

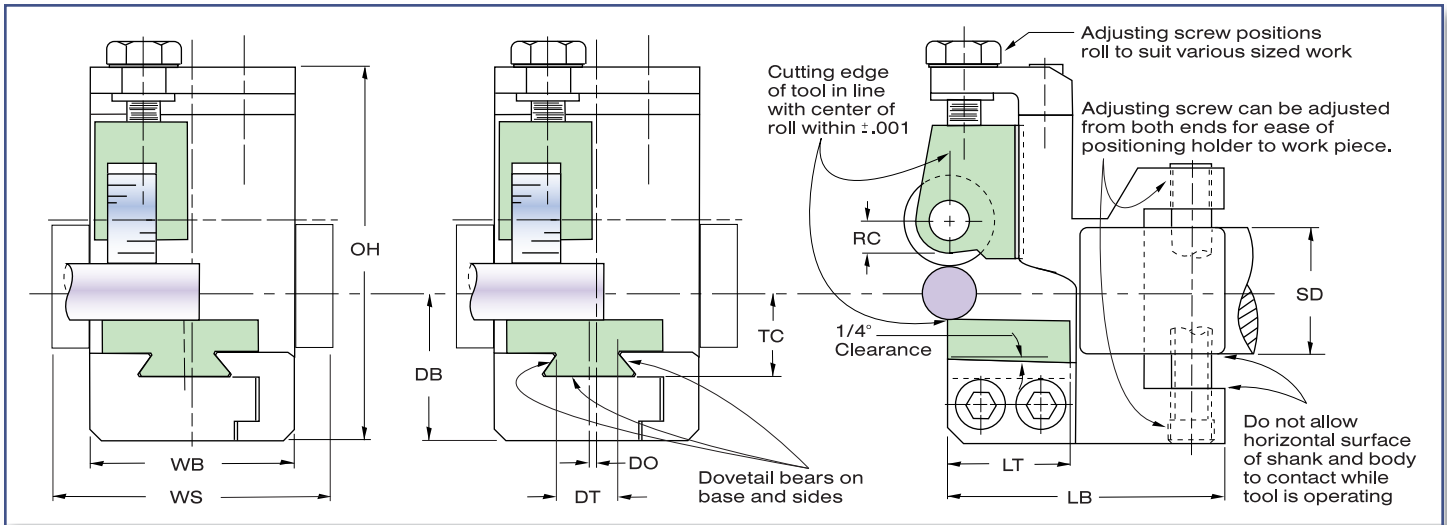

**Order #**  
**SDT-7120**  
For use with  
**5/8" Model "B"**

**Order #**  
**SDT-7125**  
For use with  
**5/8" or 7/8" Model "B"**

### Tooling Chart

Order Number	SDT-7120	SDT-7125
Max. Capacity	5/8	7/8
Min. Capacity	0	1/4
(OH) Overall Height	2-29/32	3-5/32
(WS) Width of Shank	1-3/16	1-3/16
(WB) Width of Body	1-5/16	1-5/16
(DB) Depth Below	1-3/16	1-5/16
(RC) Roll Clearance	7/32	7/32
(LB) Length of Body	2-1/4	2-1/4
(LT) Length of Tool	1-1/16	1-1/16
(DT) Dovetail Size	1/2	1/2
(SD) Shank Diameter	1	1
(TC) Tooling Constant	11/16	13/16
(DO) Dovetail Offset from CL	3/32	3/32

Shaving dovetail toolholders are used to secure extremely close tolerances by removing up to .010 in. of stock over a portion of the work piece that has been previously machined.

## 2nd ("B") Position - Cross Slide

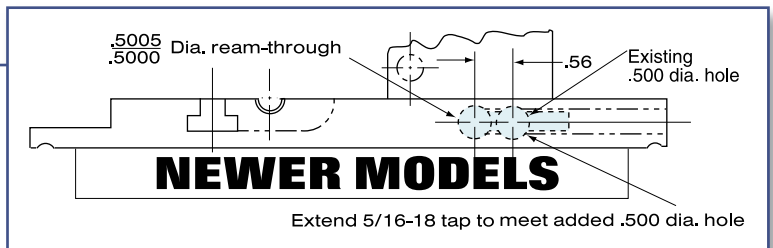
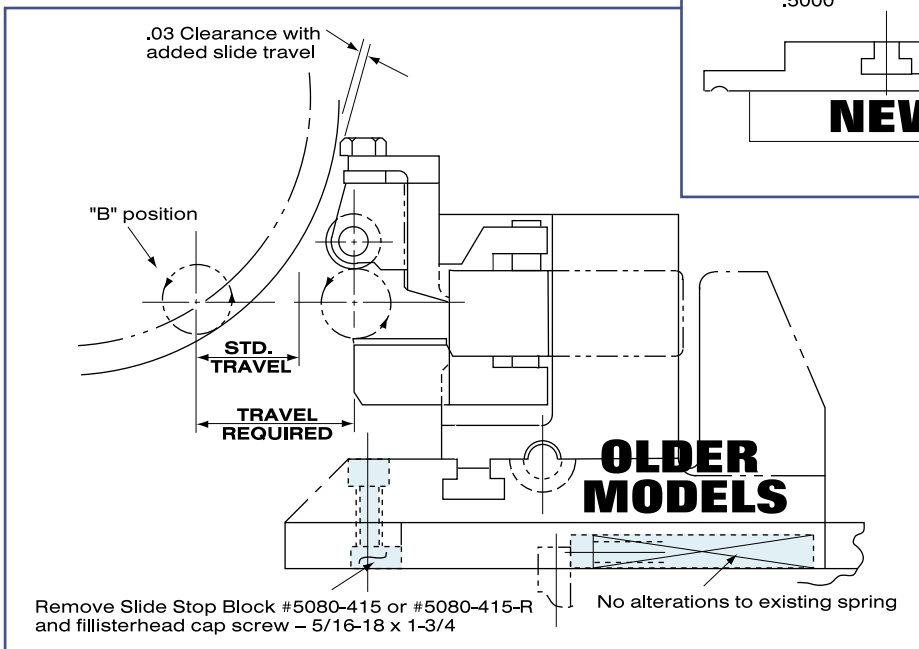

Machine Model	Position	Bore A	Holder Capacity
Model "B"	2nd / "B"	1"	5/8, 7/8

