

FORMING

Forming Circular Tool Holder

Slater Vertical Slide

For use with 5/8" or 7/8" Model "B" Davenport

Forming circular toolholders use circular tooling which is used for heavy forming cuts.

Order # **FCT-7920**

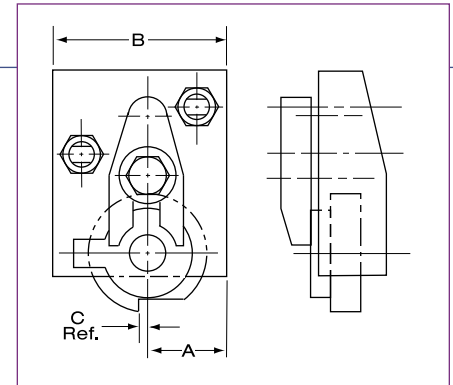

Machine Model	Position	Circular Tool Size	A	B	C
Model "B"	4th / "D"	2" Max.	1-1/2	3	1/8

Forming Dovetail Tool Holder

Direct Mount

For use with 5/8" or 7/8" Model "B" Davenport

Forming dovetail toolholders use dovetail-shape tooling. Tool sharpening is quick and will not affect tool profile.

Order # **FDT-7530**

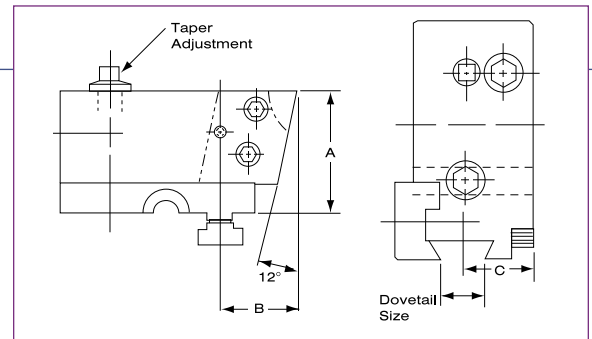

Machine Model	Position	Dovetail Size	A	B	C
Model "B"	1st / "A"	5/8	1.825	1-3/16	3/4

Forming Dovetail Tool Holder

Direct Mount

For use with 5/8" or 7/8" Model "B" Davenport

Forming dovetail toolholders use dovetail-shape tooling. Tool sharpening is quick and will not affect tool profile.

Order # **FDT-7535**

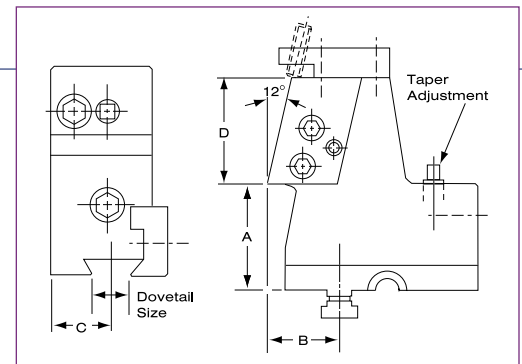

Machine Model	Position	Dovetail Size	A	B	C	D
Model "B"	2nd / "B"	5/8	1.825	1-3/16	3/4	1-13/16

Forming Dovetail Tool Holder

Direct Mount to Slater Vertical Slide

For use with 5/8" or 7/8" Model "B" Davenport

Order # **FDT-7230**

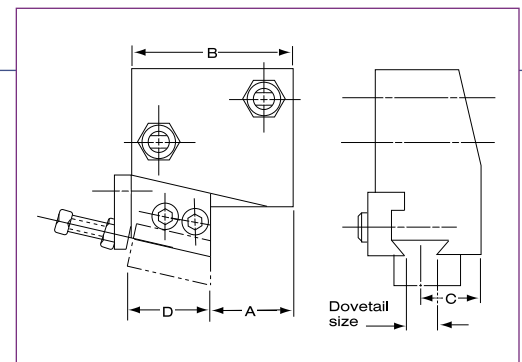

Machine Model	Position	Dovetail Size	A	B	C	D
Model "B"	4th / "D"	5/8	1-1/2	3	1-11/64	1-1/2