

Shaving Dovetail Tool Holder

Index Plate Type

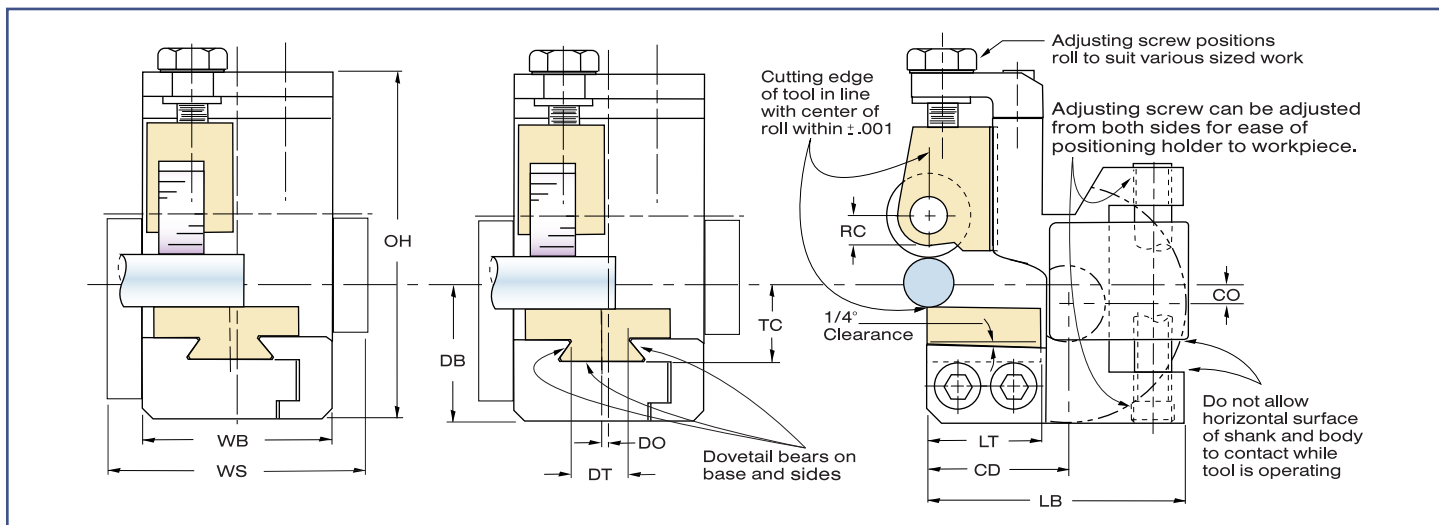

Tooling Chart

| | Order Number | SDT-7720 | SDT-7725 |
|------|-------------------------|----------|----------|
| | Max. Capacity | 5/8 | 7/8 |
| | Min. Capacity | 0 | 1/4 |
| (OH) | Overall Height | 2-7/8 | 3-5/32 |
| (WS) | Width of Shank | 1-3/4 | 1-3/4 |
| (WB) | Width of Body | 1-5/16 | 1-5/16 |
| (DB) | Depth Below | 1-3/16 | 1-5/16 |
| (RC) | Roll Clearance | 7/32 | 7/32 |
| (LB) | Length of Body | 2-1/4 | 2-1/4 |
| (LT) | Length of Tool | 1-1/16 | 1-1/16 |
| (DT) | Dovetail Size | 1/2 | 1/2 |
| (SD) | Centerline Offset | 1/8 | 1/8 |
| (TC) | Tooling Constant | 11/16 | 13/16 |
| (DO) | Dovetail Offset from CL | 3/32 | 3/32 |
| (CD) | Center Distance | 1-1/4 | 1-1/4 |



Order #
SDT-7720
For use with
5/8" Model "B"

Order #
SDT-7725
For use with
5/8" or 7/8" Model "B"

Shaving dovetail toolholders are used to secure extremely close tolerances by removing up to .010 in. of stock over a portion of the work piece that has been previously machined.

2nd ("B") Position

O.E.M. Cross Slide

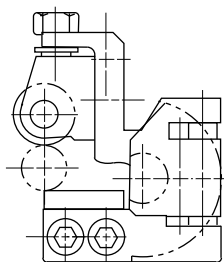

"D" Position
(4th Position)

"C" Position
(3rd Position)

3rd ("C") Position

O.E.M. Swing Arm

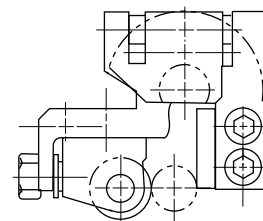

4th ("D") Position

O.E.M. Vertical Slide